

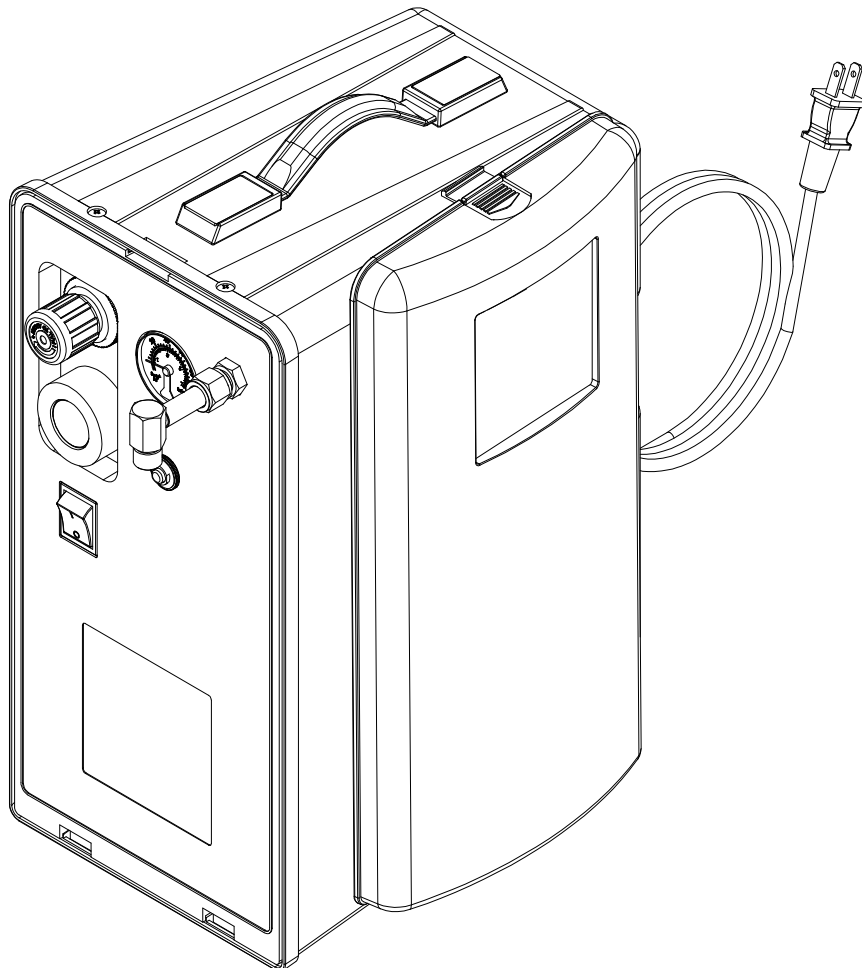

MODEL 7050
50 PSI Compressor
Operator's Manual



CONTENTS

	Page No.
INSPECTION.....	1
GENERAL INFORMATION.....	1
SAFETY PRECAUTIONS.....	2
BASIC OPERATING COMPONENTS.....	3
OPERATING INSTRUCTIONS.....	4
-Initial Positioning and Installation.....	4
-Operation.....	4
ROUTINE MAINTENANCE.....	5
-Removing and Cleaning the Air Intake Filter.....	5
SPECIFICATIONS.....	6
TROUBLE SHOOTING.....	7
SYMBOLS.....	7
LIMITED WARRANTY.....	8

INSPECTION

Upon receiving your Probasics Model 7050 Compressor, inspect the packaging for signs of damage in transit. Inspect the unit thoroughly. Any sign of damage, external or internal, should be reported to your Homecare Dealer immediately.

GENERAL INFORMATION

This manual provides information necessary to operate the Probasics Model 7050 50 PSI Compressor. This unit is designed for efficient, continuous high pressure performance. The Model 7050 Compressor provides high pressure which clinical studies have indicated are required for optimal particle size (2 microns or less).

The unit operates quietly and effectively due to the unique design of the WOBL piston. This unit operates using standard 120 VAC current, it is easy to clean, very low maintenance, compact, light-weight, and portable. The unit is designed for use with:

- Compatible with hand-held nebulizer system.
- Heated nebulizer.
- Dual action humidifier/nebulizer.
- Pediatric mist tent.
- High output pneumatic nebulizer .
- Deluxe nebulizer with oxygen diluter.
- Child / adult mist tent.

SAFETY PRECAUTIONS

When using electrical products, especially when children are present, basic safety precautions should always be followed. Read all instructions before using.

Important information is highlighted by these terms:

 **DANGER**

Urgent safety information for hazards that will cause serious injury or death.

 **WARNING**

Important safety information for hazards that might cause serious injury.

 **CAUTION**

Information for preventing damage to the product.

 **NOTE**

Information to which you should pay special attention.

READ ALL USER'S MANUAL BEFORE USING.

SAVE USER'S MANUAL

 **Note**

Connect power cord and plug to properly grounded wall outlet or adapter.

 **Note**

Unplug the power cord when it is necessary to disconnect AC power source.

 **Note**

The NCA01 TRITON-Comp. is not designed to drive ventilators.

 **Note**

Follow the national requirement to dispose unit.

 **Caution**

Ingestion of aerosols into the compressor may result in damage to the unit and void the limited warranty.

BASIC OPERATING COMPONENTS

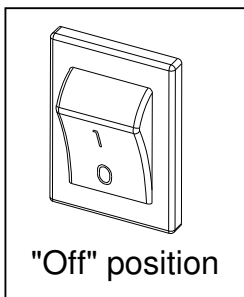
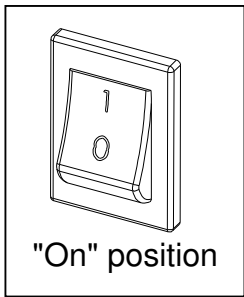
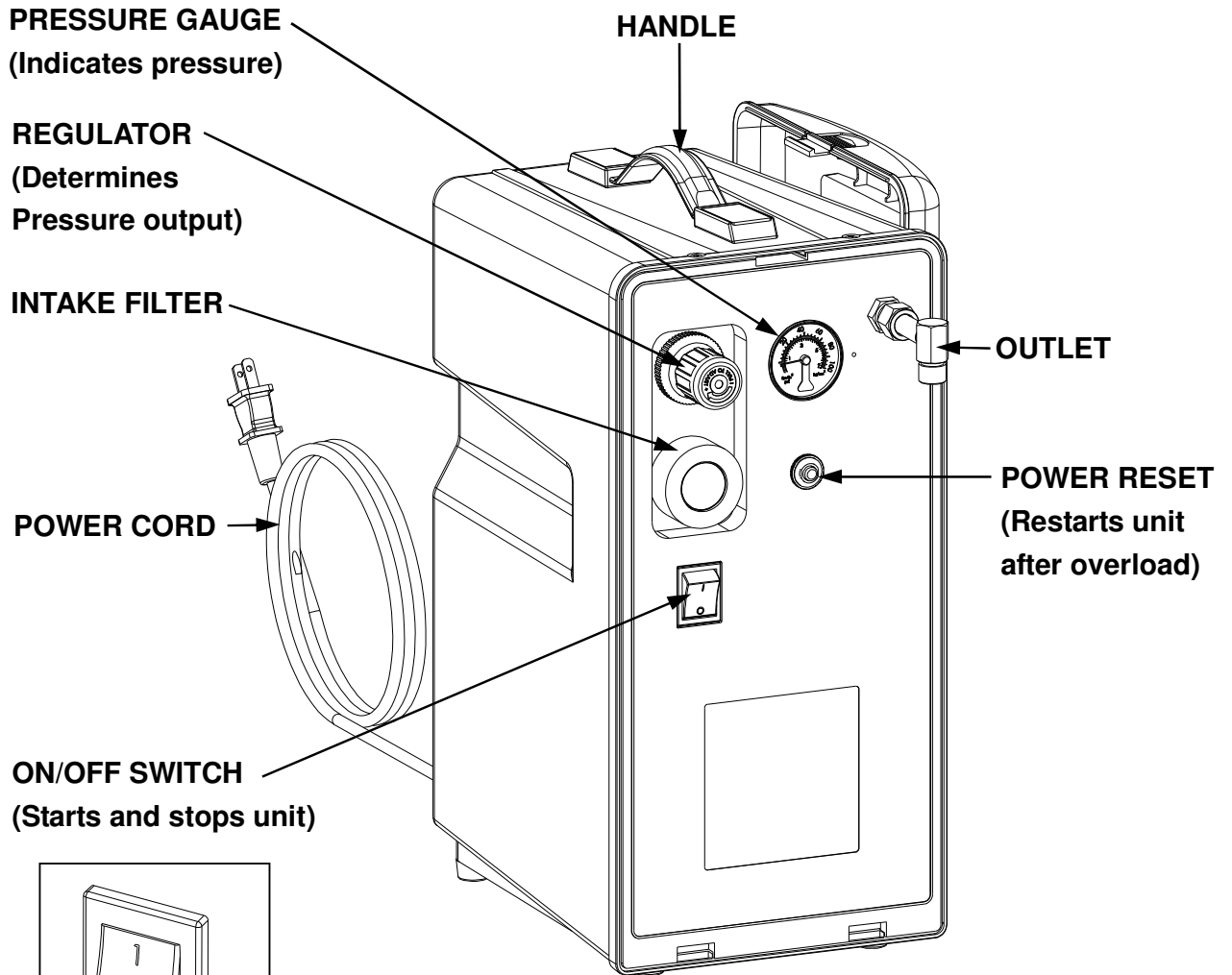

FIGURE 1

OPERATING INSTRUCTIONS

INITIAL POSITIONING AND INSTALLATION

1. Select a suitable location for the unit near a 120 VAC, 15 Ampere, grounded power outlet.
2. Grasp handle on top of cabinet and position the unit so that operating controls are Accessible to the user and back of unit is away from wall.
3. Make certain that the power switch located in the center of the control panel is in the OFF position (Figure 1) and plug power cord into grounded power outlet or grounded adapter.
4. Be certain that all connections to outlet (i.e. tubing , nebulizers , etc.) are snug and not leaking aerosol.
5. When used in conjunction with mist tents, etc., place unit outside of tent and place unit at a level below discharge end of the delivery tubing.

OPERATION

1. Press Power On/Off switch to ON position (figure 1).
2. Connect the equipment you intend to use with the Probasics Model 7050 compressor and then adjust the pressure that the unit is delivering by adjusting the regulator (figure 1) as follows:
 - a. Pull regulator knob out to unlock adjustment.
 - b. Turn dial of regulator to desired pressure.
 - clockwise – increase pressure
 - counter clockwise – decrease pressure
 - c. Push knob towards unit locking regulator pressure.

...and observe the pressure gauge – adjust up or down to desired output pressure.

ROUTINE MAINTENANCE

REMOVING AND CLEANING/REPLACING THE FILTERS

Pull air intake filter out from front of unit (figure 1) and replace a new one when dirty. Do not wash it.

Pull cabinet filter out from back of unit (figure 2) and wash in warm soapy water and rinse weekly. Use a soft absorbent towel to remove excess water and place filter back in unit. User is requested to perform and record when the filters are replaced or cleaned.

⚠ Caution

Do not submerge in water as this will result in damage to the vacuum pump.

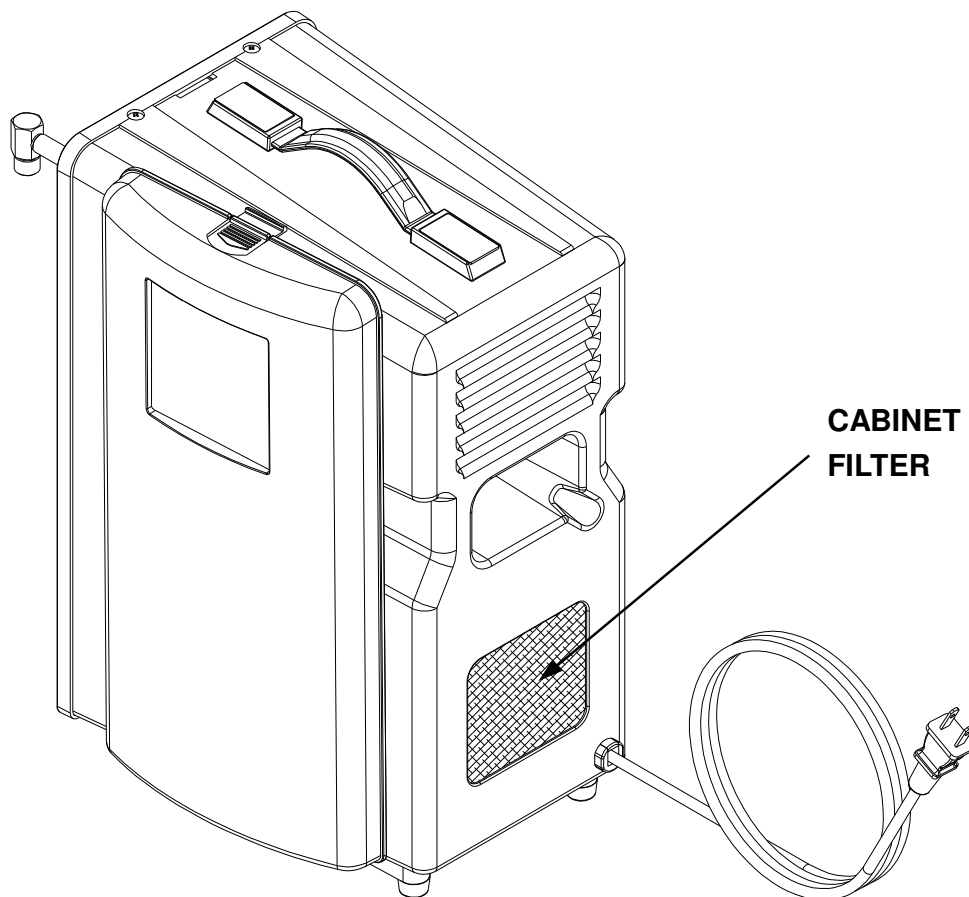

FIGURE 2

SPECIFICATIONS

Size (L) x (W) x (H) 12.2 x 7.7 x 15.3 in (310 x 196 x 390 mm)

Weight 17.2 lbs (7.8kg)

Model	NCA01L
Electrical Requirements	115 VAC ~ 60Hz
Flowrate @ Pressure	
0	41
10	34
20	27
30	22
40	16
50	11
Power Consumption (W) @ 0 PSI	170

Operating Temperature range 50° F~ 104° F (10 ~ 40°C)

Operating Relative Humidity 95%

Storage & Transport Temperature/Relative Range room condition preferred

Circuit Breaker 5A 125/250 VAC

Equipment Classifications With respect to protection from

Electrical shock Class II

Electrical hazard protection class: Type B

Degree of protection against the ingress of water: IPX0- Protection is not provided.

No AP/APG: Equipment not suitable for use in the presence of a flammable anaesthetic mixture with air/oxygen or nitrous oxide.

TROUBLE SHOOTING







If the Probasics Model 7050 Compressor malfunctions, refer to the trouble shooting chart below for probable cause and remedy. If the unit fails to operate correctly after using the troubleshooting chart below, contact your Homecare Dealer for further assistance.

TROUBLE SHOOTING CHART

TROUBLE	PROBABLE CAUSE	REMEDY
A. Unit not operating	1. Plug not firmly in wall. 2. No power at wall outlet	1. Check plug at outlet . 2. Check power source, fuse in house
B. Limited air flow	1. Faulty Delivery Tubing. 2. Leak Blocked intake filter.	1. Disconnect delivery tubing at outlet . If proper flow is restored, check equipment and tubing for obstructions or kinks. Replace if needed. 2. Check fitting at outlet and tubing. 3. Replace air intake filter.
C. All other problems		1. Contact Homecare Dealer.

Symbols

UL 60601-1 Table DI, IEC symbols

Symbol	IEC Publication	Description
	787-02-02	Type B Equipment
	348	Attention, consult ACCOMPANYING DOCUMENTS
	417-5008	Off (power: disconnection from the mains)
	417-5007	On (power: connection to the mains)
	417-5032	Alternating current
	417-5172	Class II Equipment
	417-5031	Direct Current

LIMITED WARRANTY

The compressor portion of the Probasics Model 7050 Compressor is warranted to be free from defective workmanship and materials for a period of one year from date of purchase by the dealer, as a result of normal use and service for purpose for which it was intended, as determined by PMI. PMI will replace the part or parts so determined by it to be defective with new/rebuilt parts. Any defective part(s) will be repaired or replaced at PMI's option. The Homecare Dealer must obtain prior approval from PMI before returning the unit for repair.

 **NOTE**

This warranty does not cover providing a loaner unit, compensating for costs incurred in rental while said unit is under repair, or costs for labor incurred in repairing or replacing defective part(s).

THERE IS NO OTHER EXPRESS WARRANTY. IMPLIED WARRANTIES, INCLUDING THOSE OF MERCHANTABILITY AND FITNESS FOR A PARTICULAR PURPOSE, ARE LIMITED TO THE DURATION OF THE EXPRESS LIMITED WARRANTY AND TO THE EXTENT PERMITTED BY LAW ANY AND ALL IMPLIED WARRANTIES ARE EXCLUDED. THIS IS THE EXCLUSIVE REMEDY AND LIABILITY FOR CONSEQUENTIAL AND INCIDENTAL DAMAGES UNDER ANY AND ALL WARRANTIES ARE EXCLUDED TO THE EXTENT EXCLUSION IS PERMITTED BY LAW. SOME STATES DO NOT ALLOW LIMITATIONS ON HOW LONG AN IMPLIED WARRANTY LASTS, OR THE LIMITATION OR EXCLUSION OF CONSEQUENTIAL OR INCIDENTAL DAMAGES, SO THE ABOVE LIMITATION OR EXCLUSION MAY NOT APPLY TO YOU.

This warranty gives you specific legal rights, and you may also have other rights, which vary from state to state.

For Service Call Your Authorized Probasics Homecare Dealer:



15 South Main Street
2nd Floor
Marlboro, New Jersey 07746

Phone: 732-683-1900
Fax: 732-683-1945
www.pmiusa.biz